

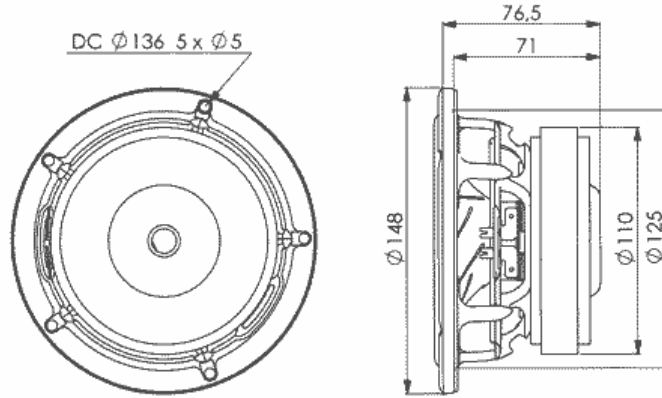

15W/4531G00

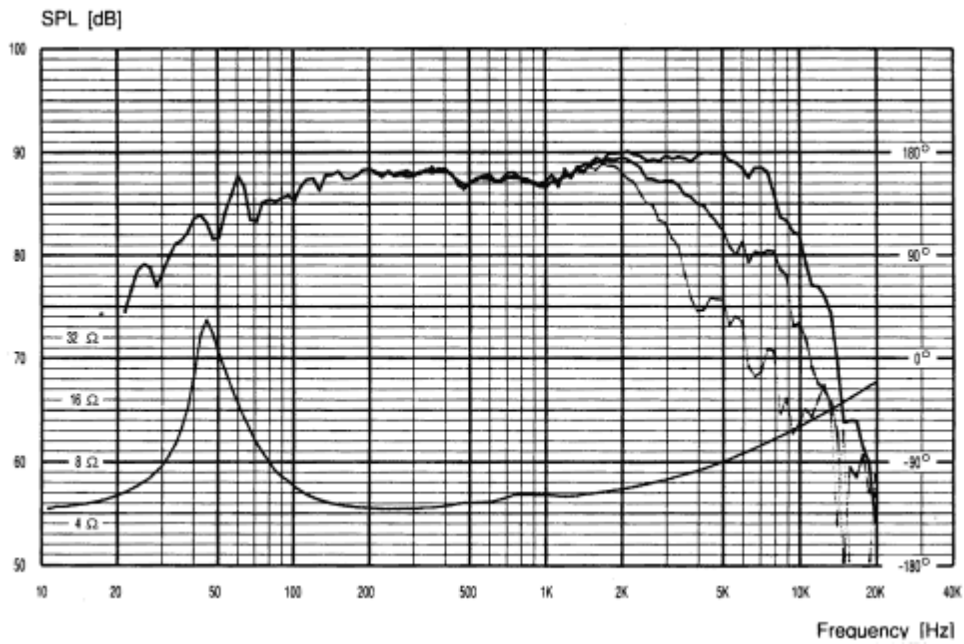

Characteristic sensitivity (2.83V / 1m)	: 87 dB
Recommended frequency range	: 30 - 6000 Hz
Free air resonance frequency, f_s	: 39.5 Hz
DC resistance, R_e	: 3.4 ohm
Voice coil inductance, L_e	: 0.25 mH
Effective piston area, S_d	: 95 cm
Moving mass incl. air, m_d	: 13 g
Mechanical loss, R_m	: 0.7 Ns/m
Force factor, BL	: 5.7 Tm
Equivalent volume, V_{as}	: 16 ltr.
Mechanical Q-factor, Q_{ms}	: 4.6
Electrical Q-factor, Q_{es}	: 0.34
Total Q-factor, Q_{ts}	: 0.32
Excursion, lin./max.	: $\pm 6.5 / \pm 9$ mm
Voice coil diameter	: 38 mm
Rated power handling	: 60 W
Net weight	: 1.6 kg



Frequency response: 2.83V / 1m