

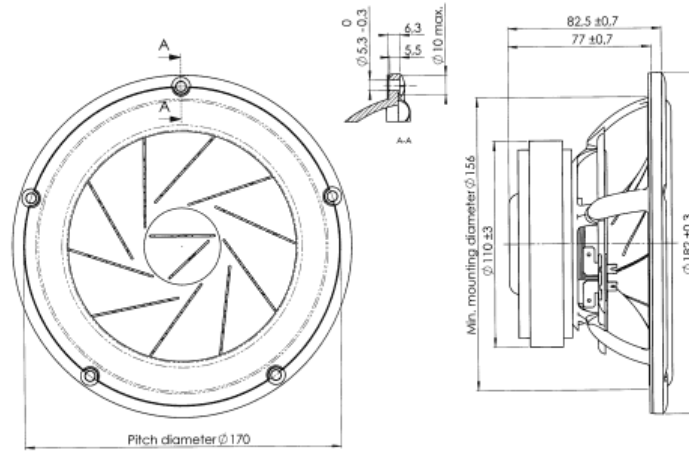

18W/4531G00

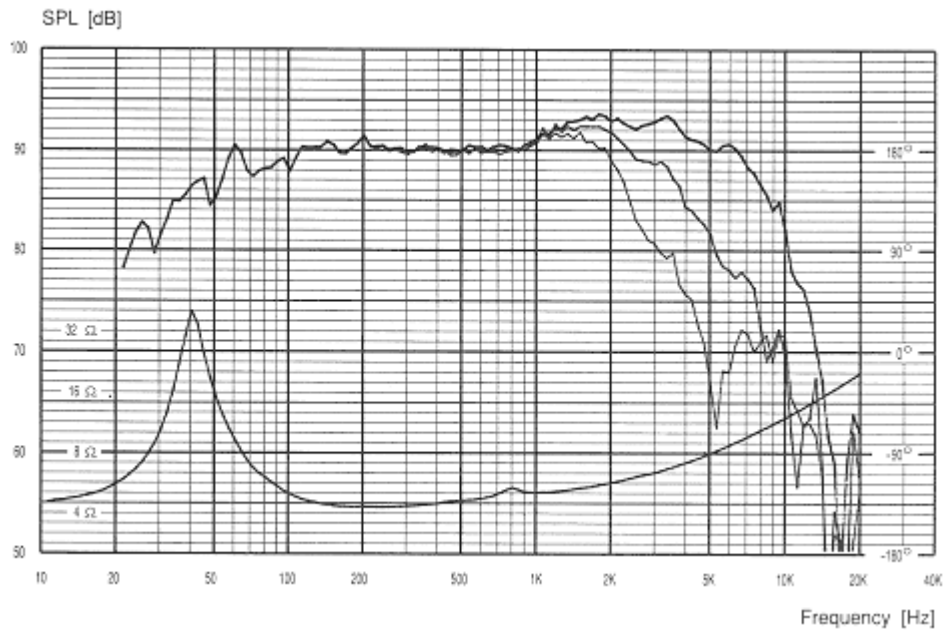

Characteristic sensitivity (2.83V / 1m)	:	90 dB
Recommended frequency range	:	33 - 5000 Hz
Free air resonance frequency, f_s	:	33 Hz
DC resistance, R_e	:	3.4 ohm
Voice coil inductance, L_e	:	0.3 mH
Effective piston area, S_d	:	150 cm
Moving mass incl. air, m_d	:	17.5 g
Mechanical loss, R_m	:	0.7 Ns/m
Force factor, BL	:	5.7 Tm
Equivalent volume, V_{as}	:	42 ltr.
Mechanical Q-factor, Q_{ms}	:	5.2
Electrical Q-factor, Q_{es}	:	0.38
Total Q-factor, Q_{ts}	:	0.35
Excursion, lin./max.	:	$\pm 6.5 / \pm 11$ mm
Voice coil diameter	:	38 mm
Rated power handling	:	70 W
Net weight	:	1.75 kg



Frequency response: 2.83V / 1m